



**I-181**  
SEP 2013  
Revision 0

# ***Single-Stage Oil Pump 42V Oil Lubricated Mechanical Seal***

## **INSTALLATION, OPERATION AND MAINTENANCE INSTRUCTIONS**

Part Number: \_\_\_\_\_

Serial Numbers: \_\_\_\_\_

 These operating instructions contain fundamental information and precautionary notes. Please read the manual thoroughly prior to installation of unit, electrical connection and commissioning. It is imperative to comply with all other operating instructions referring to components of individual units.

 This manual shall always be kept close to the unit's location of operation or directly on the pump set.

This page left intentionally blank.

### SERVICE RECORD PAGE

Service No. \_\_\_\_\_ Model \_\_\_\_\_ Size and Type \_\_\_\_\_

Customer Order No. \_\_\_\_\_ Date Installed \_\_\_\_\_

Installation Date	Location	Application

### PUMP RATING

Capacity \_\_\_\_\_ Total Head \_\_\_\_\_

Suction Pressure \_\_\_\_\_ Speed (RPM) \_\_\_\_\_

Liquid pumped \_\_\_\_\_ Temperature \_\_\_\_\_

Specific Gravity \_\_\_\_\_ Viscosity \_\_\_\_\_

Port Width (inches) \_\_\_\_\_

### PUMP MATERIALS

Casing \_\_\_\_\_ Impeller \_\_\_\_\_ Shaft \_\_\_\_\_

Gaskets \_\_\_\_\_ Bearing Frame \_\_\_\_\_

Mechanical Seal/Packing \_\_\_\_\_

### MOTOR DATA

Motor \_\_\_\_\_ Make \_\_\_\_\_ Serial No. \_\_\_\_\_

Type \_\_\_\_\_ Frame \_\_\_\_\_ AC or DC \_\_\_\_\_

HP \_\_\_\_\_ RPM \_\_\_\_\_ Volts \_\_\_\_\_

Phase \_\_\_\_\_ Cycles \_\_\_\_\_

**NOTES ON INSPECTION AND REPAIRS**

INSPECTION DATE	REPAIR TIME	REPAIRS	COST	REMARKS

# INSTALLATION, OPERATION AND MAINTENANCE INSTRUCTIONS

## TABLE OF CONTENTS

SECTION/PARAGRAPH	PAGE	SECTION/PARAGRAPH	PAGE
I. GENERAL DESCRIPTION AND SAFETY		VI. MAINTENANCE .....	7
PRECAUTIONS.....	1	A. Lubrication of Pump Bearings and Bushings .....	8
A. General Information .....	1	B. Lubrication of Motor .....	8
B. Disclaimer .....	1	C. Torque Values.....	8
C. Personnel Qualification and Training .....	1	VII. SERVICE AND REPAIR.....	8
D. Pump Identification.....	1	A. Preparations for Disassembly of Pump .....	8
E. Parts Inventory Guide .....	2	B. Disassembly of Pump .....	9
F. Parts Ordering.....	2	C. Parts Inspection .....	10
G. Safety Precautions .....	2	D. Reassembly of Pump.....	11
II. INSPECTION AND STORAGE .....	3	E. Replacement of Mechanical Seal .....	12
A. Inspection.....	3	F. Motor .....	13
B. Storage of Pump .....	3	G. Coupling.....	13
III. INSTALLATION .....	3	H. Check Valve .....	13
A. Location.....	3	VIII. PARTS LISTS AND DRAWINGS .....	13
B. Handling .....	4		
C. Coupling Alignment.....	4	<b>LIST OF TABLES</b>	
D. Pre-Installation Procedures.....	4	<b>NUMBER</b>	<b>TITLE</b>
E. Piping .....	4	<b>PAGE</b>	
F. Auxiliary Piping Connection and Gauges.....	4	1. Pumping Unit Troubleshooting .....	6
G. Motor .....	5	2. Recommended Torque Values (ft-lbs).....	8
H. Direction of Rotation.....	5	3. Recommended Equipment .....	8
IV. OPERATION.....	5	4. Impeller Clearances .....	11
A. Pre-start Cautions .....	5	5. Recommended Spare Parts List.....	13
B. Priming .....	5		
C. Starting the Pump .....	5	<b>LIST OF ILLUSTRATIONS</b>	
D. Operating Checks .....	5	<b>NUMBER</b>	<b>TITLE</b>
E. Stopping the Pump.....	6	<b>PAGE</b>	
F. Indefinite Shutdown.....	6	1. Sling Position for Moving Pumping Unit.....	4
V. TROUBLESHOOTING OPERATING PROBLEMS.....	6	2. Sectional Assembly Drawing .....	15

This page left intentionally blank.

## I. GENERAL DESCRIPTION AND SAFETY PRECAUTIONS.



**A. GENERAL INFORMATION.** 42V Oil Pumps are vertical, single-stage, centrifugal oil pumps. Carver Pump Company products are carefully engineered and manufactured and, if properly installed, maintained, and operated, should provide maintenance-free operation and a long service life.



These instructions must always be kept close to the product's operating location or directly with the product.

This manual is designed to provide sufficient material to properly maintain the total pumping unit. The information presented should improve your knowledge and understanding of the 42V Oil Pump, thus upgrading the reliability, service life, and quality of pump maintenance.

These operating instructions do not take into account local regulations; the operator must ensure that such regulations are strictly observed by all, including the personnel called in for installation. Compliance with such laws relating to the proper installation and safe operation of the pumping equipment is the responsibility of the equipment owner and all necessary steps should be taken by the owner to assure compliance with such laws before operating the equipment. These instructions are intended to facilitate familiarization with the product and its permitted use to help satisfy safety requirements. Always coordinate repair activity with operations personnel, and follow all plant safety requirements and applicable safety and health laws/regulations.

Refer to Figure 2, the sectional assembly for the location of parts identified by item numbers. Variations do exist between configurations, not all parts described in the text may be on your configuration.

These instructions should be read prior to installing, operating, using and maintaining the equipment in any region worldwide and in conjunction with the main user instructions provided. The equipment must not be put into service until all the conditions relating to safety instructions have been met.

**B. DISCLAIMER.** Information in these User Instructions is believed to be reliable. In spite of all the efforts of Carver Pump Company to provide sound and all necessary information the content of this manual may appear insufficient and is not guaranteed by Carver Pump Company as to its completeness or accuracy.

**C. PERSONNEL QUALIFICATION AND TRAINING.** All personnel involved in the operation, installation, inspection and maintenance of the unit must be qualified to carry out the work involved. If the personnel in question do not already possess the necessary knowledge and skill, appropriate training and instruction must be provided. If required the operator may commission the manufacturer/supplier to provide applicable training.

Follow instructions in this manual carefully. Factory warranty applies only when pump operates under conditions as specified on order acknowledgment, and if pump is properly installed and maintained as recommended herein. A copy of this manual should be available to operating personnel. Additional copies of this manual are available upon request from Carver Pump Company and your local distributor. For comments and/or questions about information provided, please contact Carver Pump Company or your local distributor.

**D. PUMP IDENTIFICATION.** The type of pump, pump size, operating data, and serial number are all stamped on the nameplate attached to the pump. Pump specifications should be recorded upon receipt of the pumping unit. Record all necessary information on the pump service record page and inspection and repair record provided at the front of this manual. This information must be included in all correspondence regarding the unit. This will ensure that the correct pump and/or parts are ordered in a timely manner.

**E. PARTS INVENTORY GUIDE.** To avoid unnecessary delays for maintenance, spare parts should be readily available, purchase before and keep in stock, for normal service. Most conditions will be covered if this manual is followed. For every one to three pumps, stock one spare set consisting of items listed in Table 5, Recommended Spare Parts. Part numbers correspond to Figure 2.

**F. PARTS ORDERING.** When ordering replacement parts, please specify:

- Serial number of pump (located on nameplate)
- Part name (located on parts list)
- Quantity of parts needed

Carver Pump Company may ship an interchangeable part that is not identical in appearance or symbol. This is done only if the part has been improved. Examine parts carefully upon delivery before questioning factory or company representative. Never return parts to the factory without authorization from Carver Pump Company.

If an impeller is ordered, specify diameter across blade tips. Be sure diameter was NOT trimmed further than diameter shown on Carver Pump Company records.

If a driver or driver parts are ordered, specify name of manufacturer and all other data found on the driver nameplate.

**G. SAFETY PRECAUTIONS.** The manual is designed to provide adequate instructions for the safe and efficient installation, operation, or maintenance of the pump. Failure or neglect to properly install, operate, or maintain the pump may result in personal injury, property damage, or unnecessary damage to the pump. This manual must be read and understood both by the installing personnel and the responsible trained personnel/operators prior to installation and operation, and it must always be kept close to the location of the pumping unit for easy access.

### G.1 Summary of Safety Marking.

The safety instructions contained in this manual whose non-observance might cause hazards to persons are specially marked with the symbol:



General hazard sign to ISO 7000 - 0434.

The word "Caution" is used to introduce safety instructions whose non-observance may lead to damage to the machine and its functions.

Instructions attached directly to the machine, e.g.

- Arrow indicating the direction of rotation
- Markings for fluid connections must always be complied with and be kept in a perfectly legible condition at all times.

Observe all note, caution or danger tags attached to the equipment or included in this manual.

### G.2 Non-compliance with Safety Instructions.

Non-compliance with safety instructions may result in personal injury, property damage, or unnecessary damage to the pumping unit. Non-compliance with these safety instructions will also lead to forfeiture of any and all rights to claims for damages. Non-compliance, can for example, result in:

- Failure of important pumping unit functions.
- Failure of prescribed maintenance and servicing practices.
- Hazard to personnel by electrical, mechanical, and chemical effects as well as explosion.
- Hazard to the environment due to leakage of hazardous substances.

### G.3 Safety Instructions for Maintenance, Inspection, and installation Work.

The operator is responsible for ensuring that all maintenance, inspection and installation work be performed by authorized, qualified personnel who are thoroughly familiar with the manual and pumping unit.

The pumping unit must have cooled down to ambient temperature, pump pressure must have been released and the pump must have been drained before working on any pumping unit.

Work on the pumping unit must be carried out during shutdown. The shutdown procedure described in the manual for taking the unit out of service must be adhered to.

Pumps handling fluids that are hazardous to personnel must be decontaminated prior to being worked on.

Immediately following completion of the work, all safety relevant and protective devices must be reinstalled and/or reactivated.

Please observe all instructions set out in the section on start-up before returning the pumping unit to service.



#### **G.4 Unauthorized Modification and Manufacture of Spare Parts.**

Modifications or alterations of the pumping unit supplied are only permitted after consultation with Carver Pump and to the extent permitted by Carver Pump. Original spare parts and accessories authorized by Carver Pump ensure safety. The use of other parts can invalidate any liability of Carver Pump for consequential damage and/or warranty.

#### **G.5 Unauthorized Modes of Operation.**

The warranty relating to the operating reliability and safety of the unit supplied is only valid if the pumping unit is used in accordance with its designated use as described in the following sections. The limits stated on the nameplate must not be exceeded under any circumstances.

## **II. INSPECTION AND STORAGE.**

**A. INSPECTION.** Upon receipt of the shipment, unpack and inspect the pumping unit and individual parts to insure none are missing or damaged. Carefully inspect all boxes and packing material for loose parts before discarding them. Immediately report any missing parts or damage incurred during shipment to the factory and to the Transportation Company and file your "damage and/or lost in shipment" claim with the carrier.

**B. STORAGE OF PUMP.** If the equipment is not to be immediately installed and operated, store it in a clean, dry, well-ventilated place, free from vibrations, moisture and rapid or wide variations in temperature.

### **NOTE**

Storage requirements vary depending on climatic environment, length of storage and equipment. For storage periods of three months or longer, contact manufacturer for specific instructions. Improper storage could damage equipment and would result in non-warranty covered restoration of non-warranty covered product failures.

When storing the pump up to three months rotate the shaft for several revolutions at least once per month to coat the bearings with lubricant, retard oxidation and corrosion, and prevent possible false brinelling.

The motor bearings should be prepared for storage according to the motor manufacturer's instructions, in the motor manufacturer's maintenance manual, which should come with the motor.

The pump throttle bushing (8) utilize oil for lubrication during operation and is self-lubricating.



For shipment and long term storage purposes the pump ball bearing shall be fogged once every 30 days during storage with a rust retardant compatible with the oil used in the system to prevent rusting.

Consider a unit to be in storage when:

1. It has been delivered to the job site and is waiting to be installed.
2. It has been installed but operation is delayed pending completion of construction.
3. There are long (30 days or more) periods between operating cycles.
4. The plant (or department) is shut down for periods of longer than 30 days.

**Measures to be taken for prolonged shutdown of installed pumping unit.** If the pumping unit remains installed a periodic check of operation is in order to make sure that the pump is always ready for instant start-up and to prevent the formation of deposits within the pump and the pump intake area. Start up the pumping unit regularly once a month or once every 3 months for a short time (approximately 5 minutes) during prolonged shutdown periods. Prior to operation check run ensure that there is sufficient liquid available for operating the pump.

## **III. INSTALLATION.**

**A. LOCATION.** The pump assembly should be located in an area that will permit periodic inspection and maintenance. Head room and access should be provided and all units should be installed in a dry location with adequate drainage. The discharge piping should be direct with as few elbows and fittings as possible.

**B. HANDLING.**



**CAUTION**

Use a hoist with adequate lifting capacity.

Do not pick up the complete unit by the motor or the pump shafts or motor lifting eyes.

If the pumping unit slips out of the sling arrangement, it may cause injury to personnel and/or damage to the pumping unit.

Moving the unit requires proper preparation and handling. Always make sure that the pump cannot slip out of the transport suspension arrangement. Four lifting eyes shall be inserted in the bolt holes on each corner of the base (18). Attach the hoisting chain to the lifting eyes. (Figure 1) The individual motor may be lifted using proper eyebolts provided by the manufacturer, but these should not be used to lift the assembled unit.

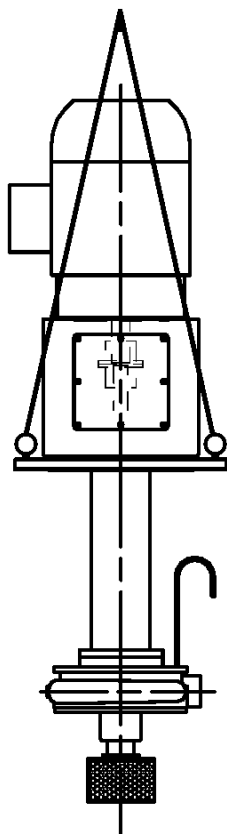

**Figure 1. Sling Position for Moving Pumping Unit**

**C. COUPLING ALIGNMENT.** The pump and motor are connected by a coupling. The base aligns the pump and motor. No further alignment is necessary.

**D. PRE-INSTALLATION PROCEDURES.**

1. Check the pump foundation and confirm the bolting surface is flat and the bolt pattern is correct.
2. Place gasket on pump foundation and slowly lower pump onto the foundation.
3. With the pump in a vertical position resting on the pump foundation, rotate the pump by hand utilizing the coupling. Check for any mechanical hesitation, binding or any acoustically transmitted signals from the pump. Hand rotation should be smooth and silent if it is not disassemble the pump until the source of the binding is located. Eliminate the binding and reassemble. Install the pump to foundation bolting and tighten to the system torque values. The pump should be rotated frequently during the procedure to tighten down the pumping unit.
4. After the pumping unit has been completely tightened down to the foundation, confirm that there is no binding.
5. Connect the piping.

**E. PIPING.** All piping should be independently supported near the pump so that pipe strain will not be transmitted to the pumping unit.



**CAUTION**

All piping connections must be made with the pipe in a freely supported state. Do not apply vertical or side pressure to align the piping with the pump flange.

Before connecting suction, discharge, and auxiliary piping, check to see that the piping is absolutely clean internally. Any debris in the piping will be drawn into the pump passageways and can cause extreme damage. The internal diameters of the suction and discharge lines must be equal to the internal diameters of the pump suction and discharge nozzles.

**F. AUXILIARY PIPING CONNECTIONS AND GAUGES.** In addition to primary piping connections, the pump may require other connections such as gauges or drains. All these lines and gauges should now be installed.

**G. MOTOR.** See motor vendor's manual for motor information and information on connecting to the power supply.



**CAUTION**

Connection to the power supply must be effected by a trained electrician only. Check available main voltage against the data on the motor rating plate and select appropriate start-up method.

**H. DIRECTION OF ROTATION.** Correct pump rotation is indicated by an arrow on the frame adaptor. The standard direction of rotation, viewed from the motor end, is counter clockwise. The direction of rotation must agree with the arrow stamped on the pump frame or base.

## **IV. OPERATION.**

### **A. PRE-START CAUTIONS.**



**CAUTION**

Before activating the pumping unit, check to make sure there are no personnel working on the unit. Serious injury or death to personnel could result if the unit is activated while being worked on.

1. Before starting or operating the pump, read this entire manual, especially the following instructions.
2. Observe all caution or danger tags attached to the equipment.



**CAUTION**

Never run the pump dry. Close running fits within the pump are liquid lubricated. Dry running will result in pump seizure or damage.

3. Before starting the pump, the pump suction head should be completely submerged in liquid.
4. Check final alignment of pump and driver. Both shafts must turn freely by hand.
5. If excessive vibration or noise occurs during operation, shut the pump down and rotate shaft by hand. If excessive vibration or noise continues, consult a Carver representative.
6. Before starting the pump, install closed guards around all exposed rotating parts.

7. Jog starter switch on motor to check that the direction of rotation must agree with the arrow stamped on the pump frame or base.

**B. PRIMING.** Dry running a centrifugal pump can result in extensive damage and possible seizing. It is, therefore, imperative that the pump be primed prior to initial start-up and that prime must be maintained through subsequent start-stop cycles.

Follow the procedure listed below:

1. Check the level in the tank to see that the pump is submerged in liquid.
2. The pump is now primed.

### **C. STARTING THE PUMP.**



**CAUTION**

Do NOT operate pumping unit against a closed discharge system. If pump has any chance of operation against a closed system, a bypass system allowing a minimum design flow should be installed. This bypass will be satisfactory for short periods of operation. For extended periods of operation the bypass should be sized for the minimum continuous flow required by the pump.

1. Check pump for proper priming and lubrication.
2. Fully open the suction valve.
3. Open discharge valves slightly, about 1 to 1 ½ turns if pump is being started for the first time or from being turned off for overhaul. Start the pump.
4. Slowly open discharge valves and adjust pressure and flow to the appropriate operating conditions. Refer to pump nameplate and system operating procedures for design point condition.

### **D. OPERATING CHECKS.**

1. Check for undue vibration or noise. If any occurs and does not stop within a short period of time, turn off the pump. For determination of the cause and its remedy refer to troubleshooting in Section V or consult Carver Pump Company.
2. Check and record flow and pressure readings. The flow and pressure readings should be within the operating system guidelines and

similar to number stamped on the pump nameplate.

3. Check and record bearing temperature. It should not exceed 180 degrees F.
4. Check and record vibration.
5. Check and record power input to the motor.
6. Check for leakage at mechanical seal.

**E. STOPPING THE PUMP.**

1. If the pump is being stopped for overhaul, slowly close the discharge valve. Otherwise leave discharge valves set at condition.
2. Stop the pumping unit in accordance with the directions on the electrical power supply.
3. Tagout and lockout power to motor according to OSHA Standard 1910.147.

4. Close suction valve and any auxiliary fluid lines.
5. The pumping unit is now off.

**F. INDEFINITE SHUTDOWN.** Relubricate bearings. Provide pump assembly with a protective cover. Remove casing plug to drain casing. Drain all piping if there is a possibility of liquid freezing.

**V. TROUBLESHOOTING OPERATING PROBLEMS.**

If you have followed the installation and starting procedures outlined in this manual, the pump should provide reliable service and long life. However, if operating problems do occur; significant time and expense can be saved if you refer to Table 1 to eliminate the most common causes of those problems.

**Table 1. Pumping Unit Troubleshooting**

SYMPTOM	PROBABLE CAUSE	CORRECTIVE ACTION
Failure to deliver liquid.	<ol style="list-style-type: none"> <li>1. Discharge head above shutoff.</li> <li>2. Check valve stuck or improperly installed.</li> <li>3. Impeller or suction clogged.</li> </ol>	<ol style="list-style-type: none"> <li>1. Check pump rating against actual head condition.</li> <li>2. Adjust and/or reverse valve.</li> <li>3. Inspect strainer and impeller. Clean as necessary.</li> </ol>
Excessive power consumption.	<ol style="list-style-type: none"> <li>1. Head lower than rating: trying to pump too much liquid or operating at end of performance curve.</li> <li>2. Specific gravity or viscosity of oil is too high</li> <li>3. Mechanical defects such as binding rotating elements.</li> <li>4. System head lower than design condition.</li> <li>5. Incorrect impeller diameter.</li> </ol>	<ol style="list-style-type: none"> <li>1. Adjust pressure flow.</li> <li>2. Check oil temperature and adjust as necessary.</li> <li>3. Check for excessive pipe strain. Check foundation bolting. Replace defective parts.</li> <li>4. Adjust system head. Trim impellers to actual condition.</li> <li>5. Replace impeller or trim impeller to correct diameter. Consult with Carver Pump before trimming impellers.</li> </ol>
Insufficient discharge or flow.	<ol style="list-style-type: none"> <li>1. Discharge head above shutoff.</li> <li>2. Air or gases in oil.</li> <li>3. Impeller or suction partially clogged.</li> <li>4. Wrong direction of rotation.</li> <li>5. Specific gravity or viscosity of oil is too high.</li> <li>6. Incorrect impeller diameter.</li> </ol>	<ol style="list-style-type: none"> <li>1. Check pump rating against actual head condition.</li> <li>2. Adjust and/or redesign suction system. Add oil to system.</li> <li>3. Inspect strainer and impeller and clean as necessary.</li> <li>4. Reverse direction of rotation.</li> <li>5. Check oil temperature and adjust as necessary.</li> <li>6. Replace impeller or trim impeller to correct diameter. Consult with Carver Pump before trimming impeller.</li> </ol>

**Table 1. Pumping Unit Troubleshooting (Continued)**

SYMPTOM	PROBABLE CAUSE	CORRECTIVE ACTION
Vibration excessive.	<ol style="list-style-type: none"> <li>1. Foundation bolting loose.</li> <li>2. Coupling halves not properly oriented relative to each other.</li> <li>3. Impeller partially other.</li> <li>4. Wrong rotation.</li> <li>5. Insufficient foundation.</li> <li>6. Pipe strain.</li> <li>7. Bent shaft.</li> <li>8. Coupling key to motor or coupling key to pump is not correct length.</li> <li>9. Rotating equipment imbalance.</li> <li>10. Motor improperly balanced.</li> </ol>	<ol style="list-style-type: none"> <li>1. Torque bolting to proper values.</li> <li>2. Adjust coupling halves system relative to match marks.</li> <li>3. Inspect impeller and clean as necessary.</li> <li>4. Adjust direction of rotation.</li> <li>5. Stiffen foundation as necessary.</li> <li>6. Modify piping as necessary.</li> <li>7. Replace shaft.</li> <li>8. Replace with key of correct length.</li> <li>9. Replace shaft or balance impeller.</li> <li>10. Balance motor.</li> </ol>
Oil leak.	<ol style="list-style-type: none"> <li>1. Loose tube connection.</li> <li>2. Defective oil seal.</li> <li>3. Loose or defective gasket.</li> </ol>	<ol style="list-style-type: none"> <li>1. Tighten tube connectors.</li> <li>2. Replace oil seal.</li> <li>3. Tighten bolting and/or replace gasket.</li> </ol>
Bearing temperature excessive.	<ol style="list-style-type: none"> <li>1. Lubrication, insufficient lubrication.</li> <li>2. Defective bearing.</li> <li>3. Excessive or no load on bearing.</li> </ol>	<ol style="list-style-type: none"> <li>1. Lubricate according to Section VI, Paragraph A.</li> <li>2. Replace bearing.</li> <li>3. Running to close to shutoff or outside of recommended operating conditions.</li> </ol>

## VI. MAINTENANCE.

Generally the pump does not need continuous supervision. The pump should always run quietly and smoothly, without vibration. To ensure such operation, the following maintenance schedule should be applied at regular intervals during operation of the pump. Occasional visual checks are recommended. Data should be recorded for each pump to keep track of maintenance which has been performed and to note operational problems. A sample maintenance record sheet is provided for this purpose at the front of this manual.

### Daily Inspection:

- Visually inspect unit.
- Check bearing temperatures.
- Check for leakage at mechanical seals.

### Weekly Inspection:

- Check power (amps) readings.
- Check pump discharge pressure. Prescribed operating discharge pressure should never drop below 90 percent of design point pressure.
- Check vibration on pump and driver bearings. Vibration should NOT exceed 1.5 overall

displacement (unfiltered) peak to peak mils (0.001") at 3600 RPM and 3.0 overall displacement (unfiltered) peak to peak mils (0.001") at 1750 RPM.

### Monthly Inspection:

- Check coupling alignment.
- If necessary, grease coupling. Do NOT over grease.
- Check foundation bolts.

### Semi-annual Inspection:

- Check coupling alignment due to settling of foundation.
- If stand-by pumps are installed, it is advisable to operate pumps on a rotation system to give each pump a certain duty. This ensures that stand-by pumps will always be in good condition for instant start-up.

### 25000 Hours - Overhaul

- For pump overhaul; disassemble pump, complete parts inspection, and reassemble pump according to Section VII.

- Inspect volute for corrosion, erosion or other damage. 3mm limit of metal loss in suction casing and discharge casing (Items 2 and 3).

**A. LUBRICATION OF PUMP BEARINGS AND BUSHINGS.**

**Ball Bearing (10).** The pump ball bearing (10) is lubricated by pressurized oil from the pump.

**Throttle Bushing (8).** The throttle bushing (8) is lubricated by a forced oil feed system and are self-lubricating.

**B. LUBRICATION OF MOTOR.** See motor manufacturer's instructions to be sure motor bearings are properly lubricated.

**C. TORQUE VALUES.** Refer to Table 2, Recommended Torque Values. Clean and properly lubricate threads and bearing face of the fastener to obtain the proper fastener loading from these torque values. Fasteners should be tightened evenly and in stages. Refer to your torque wrench manual for the proper use of your wrench.

**Table 2. Recommended Torque Values (ft-lbs)**

Bolt Size	Material		
	Composite	Steel (or otherwise noted)	316 Stainless Steel
1/4"-20	5	5	7
5/16"-18	11	11	12
3/8"-16	18	18	21
1/2"-13	33	39	45
5/8"-11	54	83	97
3/4"-10	80	105	132
7/8"-9	109	160	203
1"-8	144	236	300

**Table 3. Recommended Equipment**

Tools	Materials	Test Equipment
Spanner Wrench Rawhide or Wood Mallet Wooden Wedge Allen Wrench Set Socket, Open, & Box Wrench Set Vice Grips Torque Wrench Bearing Heater	Oil O-ring Lubricant	Coupling Alignment Gauges Volt-Amp Meter

**VII. SERVICE AND REPAIR.**

Refer to Figure 2 to locate the pump parts by item number and parts list.

**A. PREPARATIONS FOR DISASSEMBLY OF PUMP.**

During disassembly, match mark parts so they can be replaced in their original position. All parts should be thoroughly cleaned or replaced with new, if necessary. Sealing faces should be perfectly clean. Carver Pump Company recommends that all O-rings and shims are only used once.



Factory authorized parts must be used to safely maintain your Carver Pump.

**NOTE**

To avoid damage to O-rings, check to make sure all parts are free of sharp edges or burrs.

Close suction and/or discharge valves. The pump suction casing should be cooled down to ambient temperature. The suction casing must be empty and not under pressure.

After prolonged operation, components may not be easily removed from shaft. In such instances, rust solvent may be used and suitable extracting tools applied wherever possible. Do NOT use force under any circumstances. Refer to Table 3, Recommended Equipment, for proper tooling during disassembly and assembly. Refer to appropriate sectional drawing for location of parts followed by an item number. Assemble the pump in accordance with accepted rules of engineering practice. Coat individual components with a suitable lubricant before assembling. Assembly of unit should be performed on a clean, flat surface.

While assembling the pumping unit, Carver Pump Company recommends that the following parts be replaced with new:

- O-rings / gaskets
- Shims
- Bearings
- Grease seals
- Mechanical seals

Prepare the pumping unit for disassembly using the following list:

1. Read this entire section and study the sectional view drawing, Figure 2, before disassembling the pump.



**CAUTION**

Before attempting to disassemble the pump, the electrical power supply to the driver must be locked and tagged in the "OFF" position to prevent injury or death to personnel servicing the pumping unit.

2. Stop the pumping unit; refer to Section IV, Paragraph E.



**CAUTION**

Properly decontaminate pump and piping before disconnecting the pumping unit. Applicable hazardous material procedures must be followed.

3. Slowly close discharge valves.
4. Shut off and close all valves controlling flow of liquid to and from pump. Disconnect piping and gauge line as necessary.
5. Allow pump to drain. If necessary, flush pump to remove corrosive or toxic pumpage.
6. Remove coupling guard.
7. Disconnect coupling between pump and motor. If non-spacer coupling is fitted, the driver will have to be removed from the baseplate.

**B. DISASSEMBLY OF PUMP.**



**CAUTION**

Use a hoist with adequate lifting capacity.

1. Attach hoisting chain to motor lifting eye (Refer to Figure).
2. Remove capscrews (52) and lockwashers (53) from coupling guard (42). Remove coupling guard (42). Remove guard gasket (43) from coupling guard (42). Match mark coupling (45) halves to assure proper coupling reassembly. Disconnect coupling (45) halves. If servicing motor or replacing coupling, remove coupling pin (41) and loosen setscrews to remove coupling (45) half and motor coupling key from motor shaft.

3. Remove locknuts (32) from studs (31), freeing motor from motor bracket (40). Hoist motor and motor coupling (45) half way from pump and place on plywood or heavy cardboard.
4. Disconnect piping. Remove foundation bolts from base (18). Insert one lifting eye onto each corner of the motor bracket (40) bolt holes.



**CAUTION**

Use a hoist with adequate lifting capacity.

5. Attach hoisting chain lifting eyes. Hoist pump to a suitable working area. Remove hoisting chain from lifting eyes.
6. Loosen tube connector (66 and 68) nuts and remove tubing (67) to prevent damage to tubing (67) during disassembly.
7. Remove locknuts (22) from bolts (21), separating suction cover (3) and strainer flange (64). Remove strainer flange (64), strainer nipple (47), and strainer (46) as an assembly.
8. Remove locknuts (20) from studs (19) at the suction cover (3). Remove suction cover (3) from volute (2). Remove volute gasket (17) from either the suction cover (3) or the volute (2).
9. Remove impeller capscrew (16) and impeller washer (15) from shaft (9). Remove impeller (1) from shaft (9). Remove impeller key (14).
10. Remove locknuts (26) from studs (25) in backcover (57). Remove volute (2) from backcover (57) and shaft (9). Remove O-ring (61) from backcover (57).
11. Remove locknuts (49) from studs (48) in column (4). Remove backcover (57) from column (4).

**NOTE**

If removal of throttle bushing (8) is desired for inspection, cleaning or replacement, proceed to step 12.

12. Throttle bushing (8) will remain in volute (2), unless it is necessary to replace throttle bushing (8). If replacement of throttle bushing (8) is necessary, remove setscrew (33) from volute (2). Remove throttle bushing (8) from volute (2).
13. Remove locknuts (30) from studs (29). Remove bearing frame (5) along with column (4) and shaft (9) from motor bracket (40).
14. Remove locknuts (28) from studs (27). Remove bearing cap (6) from studs (27) and from shaft (9). Remove gasket (71) from bearing cap (6).

15. Remove mechanical seal (70) from shaft (9).

**NOTE**

If bearing removal is desired for inspection, cleaning or replacement, proceed to steps 16 and 17.

16. Remove bearing frame (5) and column (4) assembly from shaft (9).
17. Uncrimp bearing lockwasher (12). Remove bearing locknut (11). Remove bearing lockwasher (12). Remove bearing (10). Remove bearing spacer (13) from shaft (9).

**C. PARTS INSPECTION.**

1. All parts should be thoroughly cleaned or replaced with new ones if necessary. All sealing faces should be perfectly clean. It is recommended that all gaskets, O-rings, and locking devices with a nylock feature be replaced with new if disturbed from position.
2. Inspect volute for pitting, scoring, and erosion. The inside of the volute should be free of any pits or grooves. Replace the volute if any of these defects are present.
3. Inspect throttle bushing for wear. Measure inside diameter of throttle bushing. If reading is greater than 1.515 inch, replace throttle bushing.
4. Inspect impeller and coupling keys for distortion and push fit into keyways. The keys should be

square on all four edges. They should fit without having to be forced. The keys should not rock in keyway. Replace keys or shaft if necessary.

5. Inspect tubing for kinking. Replace kinked tubing.
6. If the impeller (1) shows excessive wear due to erosion or pitting, so that performance cannot be restored, it must be replaced.
7. Check the impeller (1) and suction cover (3) wear clearance as follows:
  - a. Measure outside diameter of front impeller hub in three places.
  - b. Measure inside diameter of suction cover in three places.
  - c. If difference between the high reading of the inside diameter of the suction cover and the low reading of the outside diameter of the impeller hub exceeds double the maximum clearances given in Table 4, replace the impeller and/or suction cover according to Section VII, Paragraph D.
8. Inspect and clean strainer.
9. Inspect ball bearing (10) for damage. A damaged bearing must be replaced. If bearing is removed from shaft, it is recommended that the bearing be replaced. If bearing replacement is not possible and bearing is in good condition bearing should be cleaned according to Section V, Paragraph B, steps 1-3. Protect until ready to use.



**Table 4. Impeller Clearances**

MODEL (Suction x Discharge x Maximum Impeller Diameter)	FACTORY STANDARD DIAMETRIC CLEARANCE (IN INCHES)	
	Minimum	Maximum
1.25 x 1 x 5L	0.009	0.014
2 x 1.5 x 5L	0.012	0.016
2.5 x 1.5 x 5L	0.012	0.016
4 x 3 x 5L	0.016	0.020
1.25 x 1 x 7L	0.012	0.016
1.5 x 1.25 x 7BL	0.014	0.018
2 x 1.5 x 7L	0.012	0.016
2.5 x 2 x 7L	0.012	0.016
3 x 2.5 x 7L	0.014	0.018
4 x 3 x 7L	0.014	0.018
5 x 4 x 7L	0.015	0.020
1.5 x 1.25 x 9H	0.014	0.018
1.5 x 1.25 x 10H	0.011	0.014
2 x 1.5 x 10H	0.012	0.016
2.5 x 2 x 10H	0.012	0.016
3 x 2.5 x 10H	0.012	0.017
4 x 3 x 10H	0.012	0.016
5 x 4 x 10H	0.016	0.021
6 x 5 x 10BH	0.021	0.026

**D. REASSEMBLY OF PUMP.**

During reassembly, install parts as applicable.



During reassembly, install new locknuts, as they have a self-locking feature. Locknuts with a self-locking feature may not provide adequate security once disturbed from position.

During reassembly, install new O-rings, oil seals, and gaskets if disturbed from position. O-rings, oil seals and gaskets may have been damaged during disassembly.

During reassembly, Carver recommends that ball bearing (10) be replaced if disturbed from position.

**NOTE**

All parts should be thoroughly cleaned or replaced with new ones if necessary. All sealing faces should be perfectly clean.

If ball bearing (10) was removed, proceed to step 1, if not removed proceed to step 5.

1. If removed, install bearing spacer (13) on shaft (9).
2. If removed, install ball bearing (10) on shaft (9) by heating ball bearing (10) in an oven at 250 degrees F. This will expand the inner race, allowing it to slip over the shaft (9).
3. Install bearing lockwasher (12). Install bearing locknut (11) on shaft (9). Crimp tangs of bearing lockwasher (12) in grooves of bearing locknut (11).
4. Install shaft (9) in bearing frame (5).
5. Place shaft (9) in base (18). Secure motor bracket (40), bearing frame (5), and column (4) together with new locknuts (30) on studs (29).
6. Lubricate shaft (9) to facilitate installation of mechanical seal (70). Install mechanical seal on shaft (9).
7. Place bearing cap (6) on shaft (9). Secure bearing cap (6) to bearing frame (5) with new locknuts (28) on studs (27).

 **CAUTION**

During installation of throttle bushing (8), handle bearing with care. Throttle bushing (8) could be damaged, if not handled carefully.

**NOTE**

If throttle bushing (8) was removed, proceed to step 7. If throttle bushing (8) was not removed, proceed to step (8).

8. Install throttle bushing (8) in backcover (57). Secure throttle bushing (8) with setscrews (33) in backcover (57).
9. Install new O-ring (61) on backcover (57). Install backcover (57) on shaft (9). Secure backcover (57) to Column (4) with new locknuts (49) on studs (48).
10. Install volute (2) next to backcover (57). Secure backcover (57) and volute (2) together with new locknuts (26) on studs (25).
11. Install impeller key (14) in keyway on shaft (9). Install impeller (1) on shaft (9). Install impeller washer (15) and impeller capscrew (16) on shaft (9).
12. Install new gasket (17) on volute (2). Install suction cover (3) and secure to volute (2) with new locknuts (20) on studs (19).
13. Install coupling key (44) in keyway on shaft (9). Place pump coupling (45) half on shaft (9).

 **CAUTION**

Use a hoist with adequate lifting capacity.

14. Attach hoisting chain to lifting eyes that were installed on base (18). Hoist pump to installation site, placing base (18) on foundation.
15. Remove lifting eyes and replace with foundation bolts.

 **CAUTION**

Use a hoist with adequate lifting capacity.

16. Hoist motor to installation site. Place motor in position on motor bracket (40) and secure with new locknuts (32) on studs (31).
17. Confirm that the pump rotates freely.

18. Connect coupling (45) using match marks made during disassembly and align according to Section III, Paragraph C.
19. Connect piping.
20. Install new guard gasket (43) on coupling guard (42). Install coupling guard (42) and secure with lockwashers (53) and capscrews (52).
21. Remove all tags from valves and switches. Open system valves. Reconnect power supply to motor.
22. Start pumping unit in accordance with Section VI, Paragraphs A, B, C, and D.

**E. REPLACEMENT OF MECHANICAL SEAL.**

1. Slowly close discharge valves.
2. Stop the pumping unit in accordance with the directions on the electrical power supply.
3. Tagout and lockout power to motor according to OSHA Standard 1910.147.
4. Shut off and close all valves controlling flow of liquid to and from pump. Disconnect piping and gauges as necessary.

 **CAUTION**

Use a hoist with adequate lifting capacity.

5. Attach hoisting chain to motor lifting eye.
6. Remove capscrews (52) and lockwashers (53) from coupling guard (42). Remove coupling guard (42). Remove guard gasket (43) from coupling guard (42). Match mark coupling (45) halves to assure proper coupling reassembly. Disconnect coupling (45) halves.
7. Remove locknuts (32) from studs (31), freeing motor from motor bracket (40). Hoist motor and motor coupling (45) half away from pump and place on plywood or heavy cardboard.
8. Loosen tube connectors (66 and 68) and remove tubing (67).
9. Remove coupling half (45) from shaft (9). Remove coupling key (44).
10. Remove locknuts (28) from studs (27). Remove bearing cap (6) from studs (27) and from shaft (9). Remove gasket (71) from bearing cap (6).
11. Remove mechanical seal (70) from shaft (9).
12. Lubricate shaft (9) to facilitate installation of new mechanical seal (70). Install mechanical seal on shaft.

13. Install new gasket (71) on bearing cap (6). Secure bearing frame (5) to column (4). With new locknuts (30) on studs (29).
14. Continue reassembly according to Section VII, Paragraph D.

**F. MOTOR.** The motor should be maintained in accordance with the manufacturer's instructions.

**G. COUPLING.** The coupling should be maintained in accordance with the manufacturer's instructions.

**H. CHECK VALVE.** If applicable, the check valve should be maintained in accordance with the manufacturer's instructions.

**VIII. PARTS LISTS AND DRAWINGS.**

This section contains listings of parts and corresponding drawings. Figure 2 notes the recommended spare parts for this pumping unit. Figure 2 is the sectional assembly drawing with parts list.

**Table 5. Recommended Spare Parts List**

Item	Description	Item	Description
1	Impeller	28	Locknut – Bearing Cap
8	Throttle Bushing	30	Locknut – Column/Bearing Frame/Motor Bracket
9	Shaft	32	Locknut – Motor/Motor Bracket
10	Ball Bearing	43	Guard Gasket
11	Bearing Locknut	44	Coupling Key
12	Bearing Lockwasher	49	Locknut – Column/Backcover
14	Impeller Key	51	Locknut – Motor Bracket/Base
15	Impeller Washer	53	Lockwasher - Guard
16	Impeller Capscrew	61	O-Ring - Backcover
17	Volute Gasket	62	Gasket – Motor Bracket
20	Locknut – Suction Cover/Volute	70	Mechanical Seal
22	Locknut - Strainer	71	Gasket – Bearing Cap
26	Locknut – Backcover/Volute		

This page left intentionally blank.

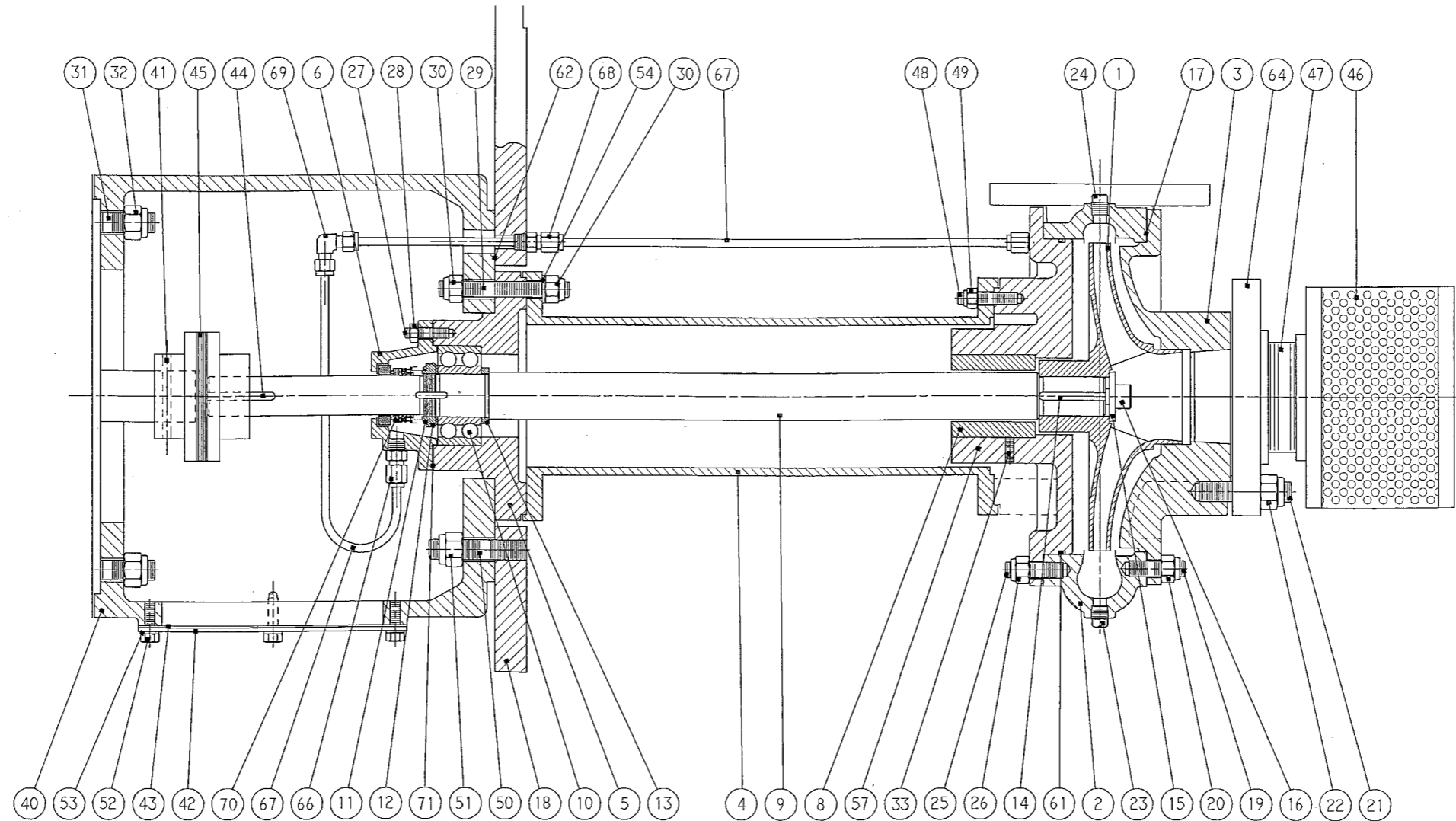

ITEM	DESCRIPTION	ITEM	DESCRIPTION	ITEM	DESCRIPTION	ITEM	DESCRIPTION
1	IMPELLER	17	VOLUTE GASKET	32	LOCKNUT - MOTOR / BRCKT.	53	LOCKWASHER - GUARD
2	VOLUTE	18	BASE	33	SETScrew - BUSHING	54	WASHER - COL./ FRAME
3	SUCTION HEAD	19	STUD - SUCT./ VOL.	40	MOTOR BRACKET	57	BACKCOVER
4	COLUMN	20	LOCKNUT - SUCT./ VOL.	41	COUPLING PIN	61	O-RING - BACKCOVER
5	BEARING FRAME	21	STUD - STRAINER	42	COUPLING GUARD	62	GASKET - MOTOR BRACKET
6	BEARING CAP	22	LOCKNUT - STRAINER	43	GUARD GASKET	64	FLANGE - STRAINER
8	THROTTLE BUSHING	23	PLUG - VOL. - 1/2 NPT	44	COUPLING KEY	66	TUBE CONNECTOR
9	SHAFT	24	PLUG - VOL. - 1/4 NPT	45	COUPLING	67	TUBING
10	BALL BEARING	25	STUD - BACKCOVER / VOL.	46	STRAINER	68	TUBE CONNECTOR
11	BEARING LOCKNUT	26	LOCKNUT - BACKCOVER / VOL.	47	NIPPLE - STRAINER	69	UNION ELBOW
12	BEARING LOCKWASHER	27	STUD - BRG. CAP	48	STUD - COL./ BCKCVR.	70	MECHANICAL SEAL
13	BEARING SPACER	28	LOCKNUT - BRG. CAP	49	LOCKNUT - COL./ BCKCVR.	71	GASKET - BRG. CAP
14	IMPELLER KEY	29	STUD - COL./ FR./ BRCKT.	50	STUD - BRCKT./ BASE		
15	IMPELLER WASHER	30	LOCKNUT - COL./ FR./ BRCKT.	51	LOCKNUT - BRCKT./ BASE		
16	IMPELLER CAPSCREW	31	STUD - MOTOR / BRCKT.	52	CAPSCREW - GUARD		

Figure 2. Sectional Assembly Drawing

This page left intentionally blank.

This page left intentionally blank.



**Carver Pump Company**

2415 Park Avenue • Muscatine, IA 52761

Phone: 563.263.3410 • Fax: 563.262.0510

[www.carverpump.com](http://www.carverpump.com)

**I-181**  
**September 2013**  
**Revision 0**